

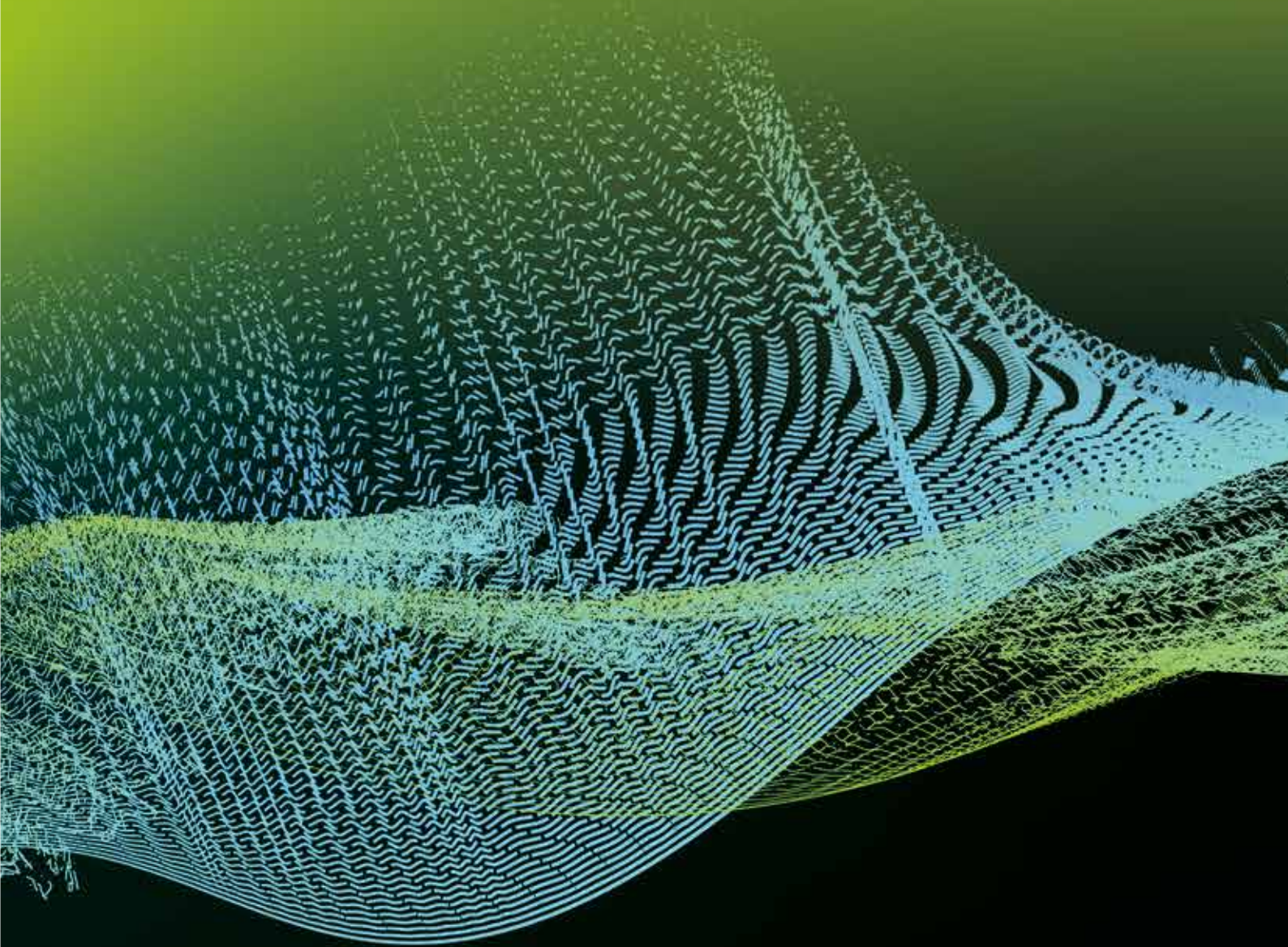

# Water infrastructure solutions

---



**EVO DIS**  
POWERED BY  Netceed

# About us

Evodis delivers top-notch energy solutions that seamlessly integrate into every project. We stand for products of outstanding quality that combine efficiency, reliability and sustainability. Our team of experts is passionate about providing comprehensive services to our clients, meticulously tailored to their unique needs.



Evodis is part of Netceed: a global leader in distribution, logistics, technical engineering, and product design with over 30 years of expertise, supporting the telecommunications, broadband and energy sectors.

Netceed's comprehensive portfolio of 90,000+ products from nearly 1,500 industry-leading suppliers, along with their value-added supply chain solutions support carriers' seamless delivery of high-speed Internet, Video, Data, and Voice services to Residential, Business, and Mobile Users, combined with an extensive know-how within the energy sector.

# Our solutions

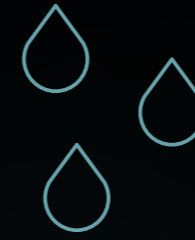

Piping

04



Valves

08



Tapping saddles

12



Meter configurations

16



Measuring and monitoring

20



Fittings

06



Couplings and clamps

10



Installation material

13



Leak detection

18



Tooling

22

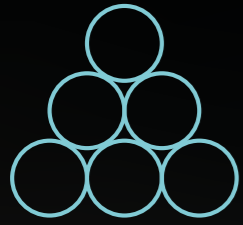

# Piping



## Steel

Our steel pipes are the lifelines of modern society, serving as critical conduits for water distribution and management. Whether for drinking water, wastewater, or industrial applications, we ensure that our steel tubes and pipes meet the most stringent requirements and specifications through advanced production technologies. Through longitudinal HFI and spiral welding, we offer a comprehensive range of diameters and lengths to meet your needs. Evodis can provide approximately 150 steel grades and several coatings and linings on demand.

## Ductile iron

Ductile iron pipes are the industry standard for modern water and wastewater systems. Their mechanical properties, along with easy installation, make them the ideal choice for a variety of uses. Known for their exceptional strength and durability, these pipes are perfect for water supply, irrigation, industrial applications, and high-pressure sewage transport.



## GRP

Glass(fibre) Reinforced Plastic (GRP) is a composite material made from a polymer matrix and glass fibres. GRP offers numerous advantages. It is lightweight yet has high mechanical strength, and it is highly resistant to chemicals and corrosion, including electrolytic corrosion, due to its non-conductive properties. GRP also withstands UV radiation and temperature changes, making it suitable for outdoor use. It is waterproof, environmentally friendly, and can be customised to be fire-retardant with non-flammable resins. GRP is a highly durable material with an exceptionally long lifespan, making it ideal for a wide range of industrial applications.

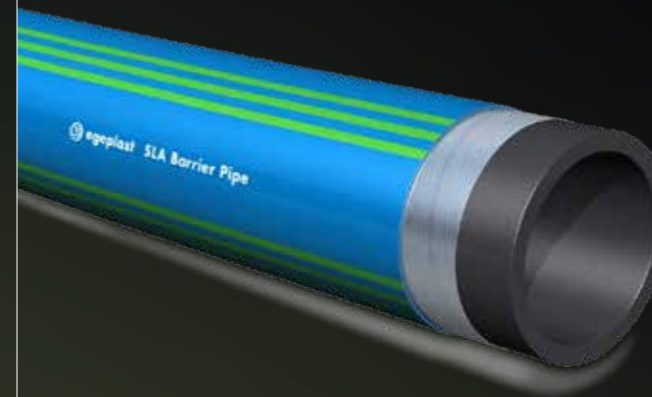

## HDPE

HDPE pipes are made from high-density polyethylene, a material known for its durability, flexibility, and resistance to corrosion. These pipes are lightweight, making them easy to handle and install. Their smooth inner surface reduces friction, allowing for efficient water flow.

HDPE pipes offer a long service life. Moreover, the combination of leak-proof joint technology and longer pipe lengths contributes to significant cost savings in the construction of gas and water supply networks, conduits, and industrial or sewage pressure piping systems worldwide.

## PVC

PVC (Polyvinyl Chloride) pipes are extensively used in drinking water systems due to their durability, resistance to corrosion, and smooth internal surface, which enhances water flow and reduces pressure loss. They meet the standards for potable water, are lightweight, cost-effective and safe, as well as offering proven recyclability.





# Fittings

## Steel

Evodis offers a range of steel fittings, including T-spools, curves, and reducers, available with either weldable ends or flange connections. In addition to our standard selection, we offer customised fittings tailored to your specific project requirements. Various coatings are available to meet your needs and we can also design and deliver both steel and GRP piping fittings.



## Ductile iron

Our ductile iron fittings are designed for exceptional strength and durability, ensuring lasting performance in water, sewage, and industrial systems. They are highly resistant to corrosion and available with flanges, socketed, or in threaded versions. These robust fittings offer efficiency and flexibility, making them essential components in the rapid construction of infrastructure networks worldwide.

## HDPE

Our HDPE fittings are versatile, lightweight, and easy to install. They offer excellent resistance to environmental and chemical stress cracking, as well as abrasion and corrosion. HDPE fittings do not deteriorate or rust due to electrolytic action. They provide long-lasting performance in gas, water, and industrial piping networks and are fully recyclable.

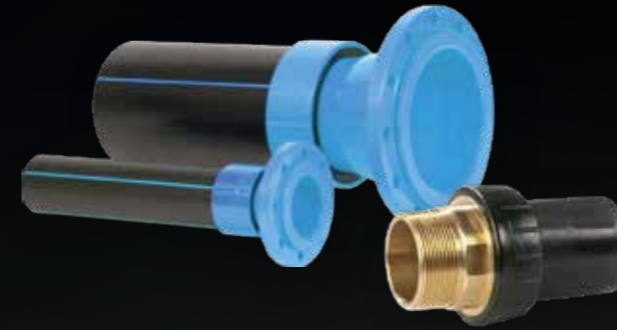

## Transition fittings

The transition fittings in our range are designed to connect pipes made from different materials. While PE-to-steel transitions are the most common, we provide fittings for any combination of materials. Available in various configurations, such as flange, PE or steel weld ends, electrofusion connections, and more, Evodis offers solutions for a wide range of needs.



## Brass, stainless steel and cast iron

Our brass, stainless steel, and cast-iron fittings are suitable for a variety of water installation connections. Depending on the size and requirements of the installation, these fittings are available in threaded, flanged, or fast connection options.



## Push-fit

Our main range of PA/PP push-fit fittings is designed for use with various types of pipes. These fittings provide a secure, end-load resistant connection that ensures a tight seal. Easy to install, these couplings offer a reliable long-term solution without the need for specialised tools.





# Valves



## Butterfly valve

Butterfly valves control flow by rotating a disc within the valve body, allowing or blocking passage. A simple quarter turn moves the valve from fully open to fully closed. These valves are a common solution in water supply, fire protection, wastewater treatment, and industrial applications. They are often used to regulate flow, and their design allows for quick opening and closure when needed.



## Gate valve

Gate valves are commonly used to stop the flow of water, allowing sections of pipe to be isolated for maintenance, troubleshooting, or cleaning. These inline valves cause minimal pressure loss during operation and provide a complete shut-off of water flow in both upstream and downstream directions. They are not designed for flow control. Gate valves are operated through multiple turns of a handwheel or manipulation key.



## Brass, stainless steel and plastic valves

Threaded valves made from brass, stainless steel, and plastic provide durability and versatility for a range of applications. Brass valves are strong and resistant to corrosion, making them ideal for high-pressure environments. Stainless steel valves offer superior durability and corrosion resistance, perfect for harsh or corrosive conditions. Plastic valves, typically made from PA, PP, or PE, are lightweight, cost-effective, and suited for non-corrosive water systems. Available in various sizes and configurations, these threaded valves ensure precise control, isolation, and regulation of water flow within the network.



## Surface boxes and access covers

Surface boxes provide access to valves, hydrants, and other utilities in water distribution systems. They allow for easy identification and maintenance of underground infrastructure, enabling efficient operations and repairs. Constructed from materials such as ductile iron, steel, or reinforced polyamide, our surface boxes vary in size from small units for valves or hydrants to large access covers for bigger chambers.

## Spindel extensions or actuators for all valves

Spindel extensions enable the manual opening and closing of underground valves. Various cover depths are available depending on the valve's burial depth. The extensions can be either fixed in height or adjustable (telescopic), and they come with different manipulation squares and protective sleeves customised for specific applications. Actuators offer precise control and automation. They are ideal for water applications due to their reliability and ease of use. Available in manual, electric, pneumatic, and solenoid-powered versions, these devices provide strong, precise power, ensuring efficient valve operation.

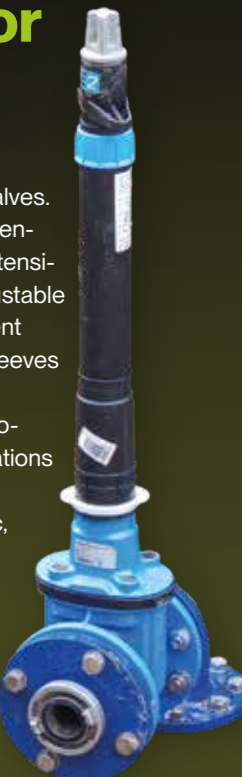

## Hydrant

Hydrants are essential components of the water network, providing access points for water supply and firefighting. Installed at strategic locations along distribution lines, they ensure reliable water flow for firefighting operations and routine maintenance. Hydrants can be positioned either above ground or underground.

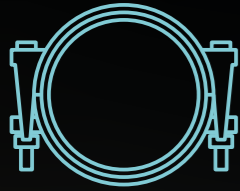

# Couplings and clamps



## Wide range couplings

Our wide range couplings, including straight, stepped reducing, and flanged adaptors, connect pipes with different outside diameters. Their compatibility with multiple pipe materials makes them ideal for quick repairs and maintenance. Our couplings are available in ductile iron, steel, or stainless steel, and come in both non-restraint and restraint versions.

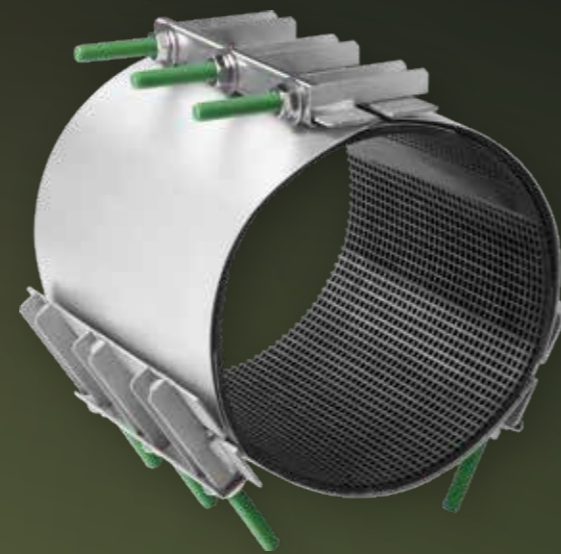

## Repair clamps

Our precision-designed repair clamps are made from high-quality materials, offering exceptional durability and strength. Engineered to handle varying pressure levels, they provide a reliable solution for quick and efficient pipeline repairs by creating a secure, leak-free seal for long-lasting performance. They come in a variety of sizes, materials, and configurations, making them suitable for a wide range of pipe diameters and applications.



## Pipe couplings

Pipe couplings offer a practical alternative to conventional pipe joining methods for plain-ended pipes. They are suitable for both plastic and metal pipes and are easy to install by hand. Their ability to accommodate pipe elongation makes them a cost-effective alternative to compensation joints. Mechanical couplings come in both restraint and non-restraint versions and are offered in various materials, including steel and stainless steel.



## Expansion joints and compensators

Expansion joints and compensators are essential solutions for managing thermal expansion, contraction, and vibration in piping systems. By increasing system flexibility, they prevent stress build-up and potential damage to pipelines and equipment. These components effectively absorb movement, extending the lifespan of system parts and ensuring continuous operation with minimal downtime. When properly selected and installed, expansion joints and compensators improve system reliability, safety, and efficiency, reducing maintenance costs and enhancing overall performance.



## Dismantling joints

Dismantling joints simplify maintenance by enabling quick disconnection and reconnection of pipelines without the need for cutting or welding.



# Tapping saddles

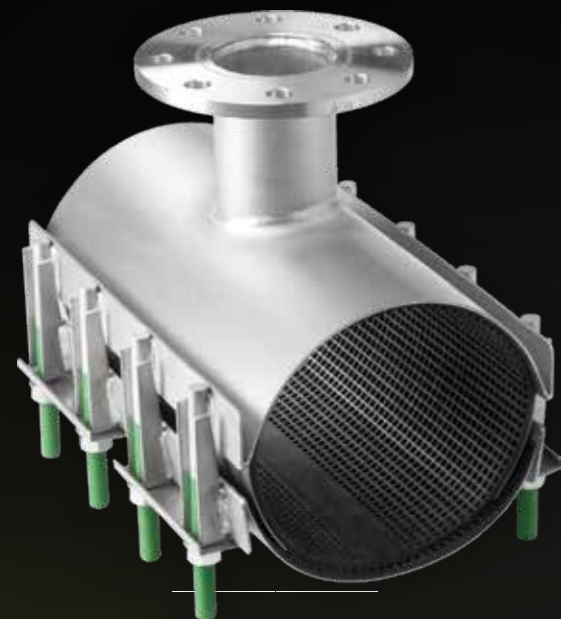

## Stainless steel

Stainless steel tapping saddles are reinforced clamps with a flanged or threaded tap. They feature a reinforced sleeve and are easy to install, making them ideal for connecting to valves, T-joints, shut-off valves, and pipe fittings. All metal components are made from stainless steel AISI 304 or AISI 316L, and have been deburred and passivated to ensure maximum corrosion resistance.

## HDPE

HDPE tapping saddles are quick and easy to install. They allow for "live tapping" of pressurised pipelines, which shortens installation time, reduces downtime, and enables new connections with minimal disruption to existing pipelines.



## Ductile iron

Our product range includes innovative, high-quality ductile iron tapping saddles. Our comprehensive selection can meet any need, offering options with or without valves, straight or angled configurations, various drilling sizes, and compatibility with multiple pipe sizes and materials.



# Installation material

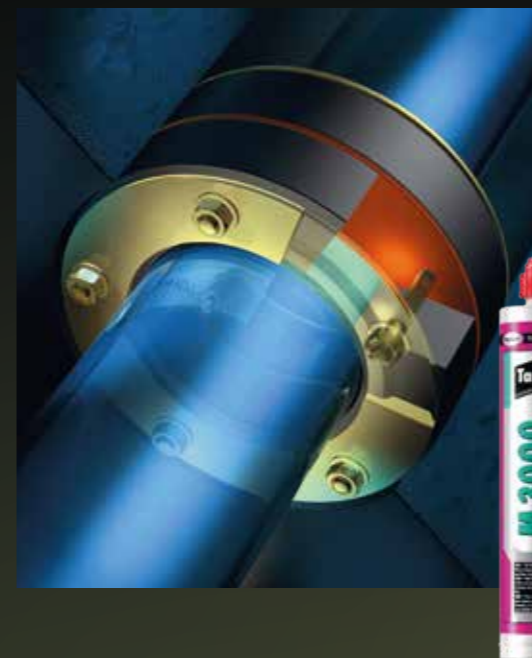

## Sealings and gaskets

Sealings and gaskets are essential components in drinking water systems, ensuring that the network remains leak-proof and free from contamination. We offer a wide variety of sealings and gaskets to suit any drinking water application.

In most buildings, supply and disposal systems are managed through underground lines. Sealing systems, also known as lead-through systems, are used to create a gastight and watertight transition between the building seal and the pipes.



## Anti-corrosion systems

Anti-corrosion systems provide mechanical protection to prevent pipes from corroding. This passive protection can be achieved using various tapes or shrink materials. Our corrosion protection systems include post-weld coatings for weld seams and fittings, as well as CP cable connections.

We also provide reliable, tailor-made solutions for re-coating steel pipes and fittings. These include shrink technology for custom-fit corrosion protection of weld seam connections and moulded parts and multi-layer plastic tape systems. Additionally, we offer traditional and proven solutions like bitumen/petrolatum tapes and high-quality PVC insulation tapes for reliable protection.



## Signposts and measuring posts

Our signalisation material helps to easily identify equipment within your network or mark distances. Our signposts are available in aluminium, steel or plastic, and we also supply materials such as identification plates, numbers and letters to suit your needs.



## Cleaning pigs

When delivering liquids, maintaining clean pipes is essential to ensure a pure, unspoilt product reaches your customers. Our pipeline pigs come in different sizes and designs, offering fast, easy and cost-efficient cleaning solutions. They are suitable for pipelines made of different materials and can also be used for several other purposes, including drying, draining or filling pipes.



## Cleaning agents and lubricants

Cleaning agents are vital for the pre-treatment of materials before welding joints. Our cleaning agents deliver excellent performance, dry without leaving any residue, and meet the hygiene standards for use with drinking water.



## Piston plugs and sealing bags

Evodis boasts a wide array of piston plugs to suit your specific application, including single, double or triple sealing rings, with or without passages. The rubber components can be supplied with or without approval for drinking water use, depending on your requirements. Additionally, we offer pipe sealing bags and test cushions in a number of sizes and connections to satisfy your unique requirements.



## Spacers, casings and seals

Our high-quality polyethylene or polypropylene casing spacers are designed to install carrier pipes within a casing pipe. By minimising friction, they allow for easy insertion of the carrier pipe and help protect its coating from damage, while meeting all requirements for cathodic pipe protection.

Casing end-seals provide a pressure-free seal for the annular space between the casing and carrier pipe. This prevents the infiltration of moisture and dirt, protecting the carrier pipe from corrosion. Our end-seals come in various shapes and sizes and are suited for new installations and retrofitting. Available in rubber, PVC or silicone, they offer a versatile solution for any application.



## Access control and locks

Evodis offers intelligent, reliable, and cost-effective locking systems for all property types and access management needs. With limitless access options, easy administration, and advanced security, our systems enable streamlined operations. Our lock technology allows you to choose between several keys options, including digital keys, NFC-enabled mobile phones (iOS or Android), fobs, tags, or PIN codes. Additionally, our systems are designed to operate without batteries or extensive cabling, simplifying installation and maintenance.



## Standpipes and hoses

We provide different types of standpipes tailored to your application. Available in different lengths and with features like DSP couplings or taps, integrated meters, and bent or straight design options, we will find the right solution for your needs. We also offer hoses in various lengths to easily transport different types of water.



# Meter configurations



## Meters

Water meters are a fundamental part of any water network and are used to measure the water consumption of residential, commercial, and industrial users. Our meters operate on various principles such as measuring the water's velocity, displacement, or electromagnetic properties. We also offer several remote monitoring options which can be integrated into the meter or managed separately.



## Brackets and meter sets

Water meter brackets are designed to hold the water meter securely in place and are usually made of durable materials such as steel or plastic. To simplify installation, we can provide a complete boxed set including all the components such as the bracket, check valves, fittings and anti-fraud seals.



## Check valves

Water check valves, also known as non-return valves, are vital components in drinking water systems to prevent the backflow of water. They ensure that water flows in one direction only, preventing contamination and maintaining system efficiency. Our check valves come in various types and materials, each suited to different applications and pressure ranges.



## Flexible hoses

Flexible hoses are used for connecting water meters to the main supply lines. Constructed from durable materials like stainless steel, these hoses offer pliability to accommodate varying installation requirements and prevent stress on the connections. They feature standard fittings for easy installation and are able to withstand water pressure and temperature fluctuations.



## Anti-fraud seals

Anti-fraud seals are a security measure implemented to prevent tampering with water meters. These seals are typically made from plastic and can feature unique markings or serial numbers for traceability. Once installed, they provide visual evidence of any attempts at manipulation or unauthorised access, ensuring the integrity of the water meter readings and the billing system.

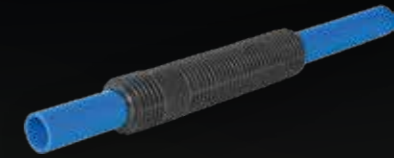

## House connections

Water transitions provide an ideal solution for wall penetrations of water pipes. Our system of round thread sheaths and flexible accessories ensures quick, safe and standards-compliant installations. Featuring a two-component sealing system, they are especially suited for wet installations. For buildings with a cellar, we offer rigid water transitions, while for buildings without a cellar, we provide flexible transitions made from PE with a factory-welded and tested protective jacket tube.



## Manifolds

Manifolds serve as distribution points, facilitating the redirection of water flow to multiple outlets. These structures consist of interconnected pipes that control the flow of water to different sections of the network. Manifolds are used for balancing water distribution, optimising pressure and ensuring efficient operation of the network. They are essential for managing water supply in complex systems such as apartment or municipal water networks.

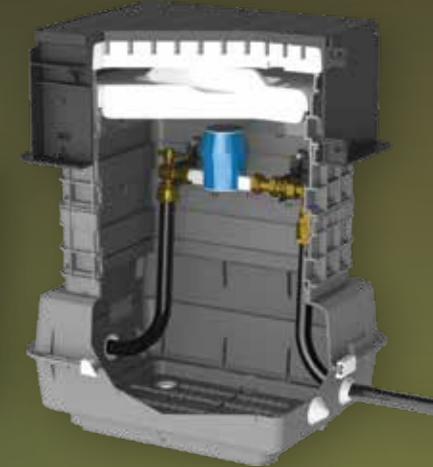

## Street cabinets

Street cabinets are essential components of water networks, providing access to valves, meters, and other utilities. They ensure efficient distribution and management of water resources, enabling timely maintenance and repairs. Typically insulated, these cabinets offer protection against the environment, vandalism and unauthorised access, safeguarding critical equipment and infrastructure. They are available in polyester or metal.

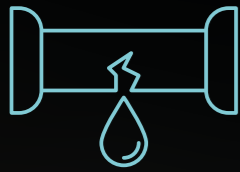

# Leak detection

## Satellite leak detection

Satellite leak detection is a non-intrusive technology that allows the inspection of large pipeline areas without the need to buy or install any equipment. It enables highly efficient leak searches by narrowing search areas to specific points of interest for further analysis.

## Noise loggers

Acoustic noise loggers can be deployed at various points in the network to detect abnormal noise patterns, indicating potential leaks. By analysing the captured sound data, operators can quickly identify areas where leaks may be occurring, allowing further analysis and prompt maintenance.



## Correlators

Correlators are devices used to pinpoint known leaks. They can be used with magnets or hydrophones and are effective both day and night. We offer various types of correlators suited for different conditions, including varying pipe materials, diameters, and environmental factors. Available in two-point or multi-point configurations, our correlators provide versatile solutions for diverse scenarios.



## Acoustic listening sticks and ground microphones

Our listening sticks and ground microphones can also be used to find leaks. Listening sticks are placed against valves, hydrants, or fittings, helping to pinpoint the location of the leak by picking up sound waves traveling through the metal. Ground microphones are used while walking above pipelines, allowing teams to listen for distinctive noises in areas where leaks cannot be seen above the surface.



## Tracer gas detection

Our tracer gas detection devices are a reliable solution for detecting leaks in both pressurised and non-pressurised pipes, where acoustic methods may be ineffective. A tracer gas mixture (5% hydrogen and 95% nitrogen) is injected into the pipe, and our precise devices detect even the smallest amounts of hydrogen escaping from a leak.

## Integrated leak detection solutions in pipe

It is also possible to integrate a monitoring unit into the pipe itself. This technology is designed to detect and report damage, even in mains-independent systems, and can be accessed and controlled in real-time via the internet. The monitoring unit triggers an alarm at the first sign of damage, no matter how small, and can automatically shut off connected pump systems, effectively preventing potential disasters at an early stage.



## Leakage management system

Various leakage management systems are available to support the use of leak detection devices. These systems streamline the process by analysing data, generating reports, and can even incorporate AI to enhance accuracy. AI-driven systems can improve the quality of the results and help prioritise points of interest, making leak detection more efficient and effective.



## Boots On The Ground (BOTG) service

Our BOTG team can help your company reduce leaks using a range of adaptable technologies. Combined with our efficient fieldwork and extensive expertise, we ensure reliable solutions for leak detection and prevention.

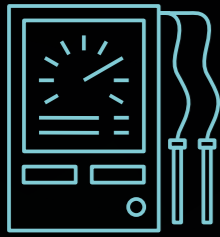

# Measuring and monitoring



## Remote datalogger

Our remote dataloggers allow for data collection from flow, pressure, and various other sensors. The logger transmits this data to a software platform, web interface, or directly to your company's system. This enables efficient data collection from difficult-to-access locations or critical points in the network, allowing for accurate monitoring and rapid response times.



## Local datalogger and pressure test equipment

Our local dataloggers are designed to measure low to mid-range pressures. They can be used in real-time or programmed to store data over a set period. The data can be extracted via local software and sent as a PDF or in other formats, depending on your needs. Additionally, certain devices can automatically approve or reject measurements and pressure tests based on customer-specific specifications.



## Manometers

A manometer is a device that measures the pressure. A multitude of classic manometers are available in our portfolio. These are available in both analogue and digital format, with or without glycerine, and come in various diameters to suit different applications.

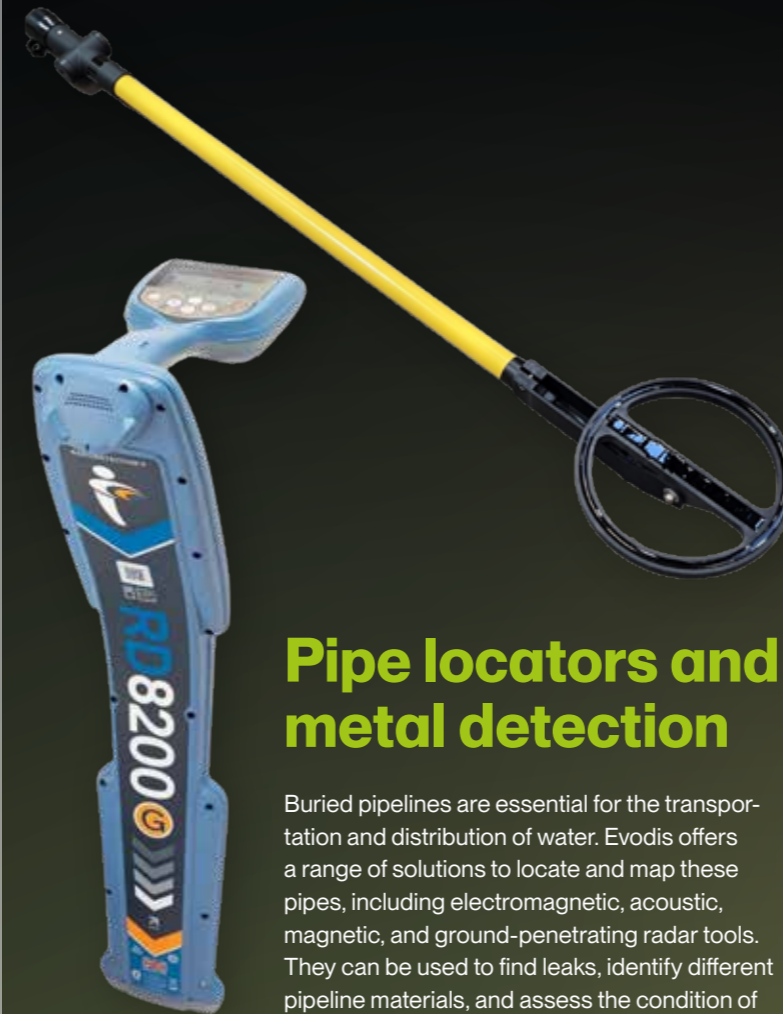

## Pipe locators and metal detection

Buried pipelines are essential for the transportation and distribution of water. Evodis offers a range of solutions to locate and map these pipes, including electromagnetic, acoustic, magnetic, and ground-penetrating radar tools. They can be used to find leaks, identify different pipeline materials, and assess the condition of metallic pipeline coatings. Our mobile apps allow for the creation of detailed maps of the buried infrastructure.

Locating manholes or other metallic covers can be challenging due to the structure of the soil or the presence of vegetation, concrete or gravel. When these access points are not visible, our extensive range of metal detectors provides an effective solution to find them with speed and precision.



## Cathodic protection

Evodis provides materials and expertise to safeguard your structures from corrosion. Our offering includes rectifiers and drainage solutions for various applications. Our product range features electrodes, anodes, and coupons, along with connectivity materials for cathodic protection (CP). We offer state-of-the-art CP dataloggers and remote monitoring systems specifically developed for precise monitoring. Additionally, we supply both above ground and underground measuring poles for installing CP cables and measuring tools.





# Tooling



## Welding machines

Evodis provides welding equipment that allows our customers to reliably and precisely weld PE and PP pipes. Our product range includes a wide variety of equipment, such as electrofusion control units, automatic butt-welding machines, and socket fusion machines, along with a comprehensive assortment of tools, accessories, and documentation software.

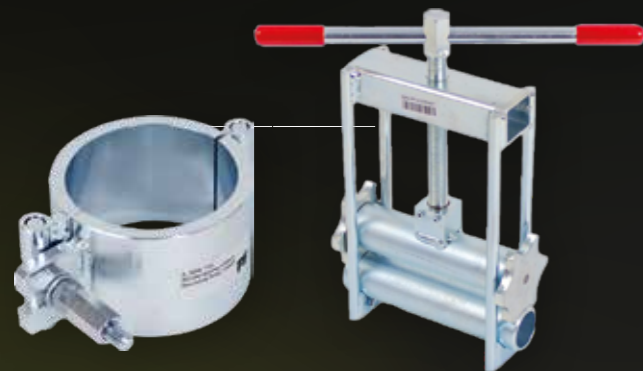

## Welding tools

We offer a wide range of tools and accessories for PE pipeline construction. Our selection includes manual, pneumatic, and hydraulic pipe cutters, squeeze tools, pipe clamps and supports, rounding and re-rounding tools, as well as peeling and scraping tools. These are just a few of the many solutions we provide.



## Drilling systems

Our hot tapping and stopple devices ensure leak-free tapping and secure shut-off of active gas pipelines. We offer complete drilling systems for steel, cast-iron, polyethylene, and cement/asbestos pipes. In addition, we provide plugging systems for low- and medium-pressure pipes, including gas bags and expanding stoppers.



## Valve and hydrant opening tools

Evodis offers a variety of keys for opening and closing valves and hydrants. Our gate valve wrenches are available in both manual and electric versions. The manual key is easy to transport and allows for quick use, while the electric wrenches are motorised (battery or mains-powered) to provide a more efficient, less physically demanding option. Hydrant keys are available in different lengths and models to meet various needs.



## Lid lifters

Our lid lifters are designed to safely and efficiently remove heavy manhole covers. These tools are essential for utility workers, reducing the physical strain and risk of injury associated with manual handling. Lid lifters are available in both mechanical versions with hooks, as well as magnetic versions, for various applications.



## Towing heads

Towing heads offer a quick, simple, and reliable way to attach a winch wire or pulling device to a plastic pipe. They eliminate the need to cut into the pipe or fuse additional fittings to create a pulling point. All towing heads are reusable and feature the "Vick" expanding internal gripper design, which tightens its grip as the pull force increases.





EVODIS  
POWERED BY  Netceed

## Get in touch

Our team of experts looks forward to helping you find the right solution for your energy project. Feel free to get in touch to discuss your project's requirements.

### **Evodis**

+32 3 253 23 50 (Temse)

+32 87 59 06 80 (Battice)

[info@evodis.be](mailto:info@evodis.be)

[www.evodis.be](http://www.evodis.be)